

ROAD DEPARTMENT FOR IONIA

170 E. Riverside Drive • Ionia, Michigan 48846 • Phone (616) 527-1700 • Fax (616) 527-8848

Linda Pigue
Managing Director

INVITATION TO BID

Sealed bids will be received until **11:00 a.m. on Friday, January 17, 2025**, at which time they will be publicly opened and read in the offices of the *Ionia County Road Department of the County of Ionia, State of Michigan*, located at 170 E. Riverside Drive, Ionia, MI 48846.

**Ionia County Road Department
Contract 25-17
HMA Countywide Paving**

It is the intent of the County of Ionia Board of Commissioners to contract for HMA Countywide Paving. The contractor shall certify that all services & materials meet current Michigan Department of Transportation specifications. All bids will meet or exceed the specifications established by the Ionia County Road Department of Ionia County and/or the Michigan Department of Transportation.

Further information upon which bids shall be based is available at www.ioniacountyroads.org on the "Doing Business" page, or www.ioniacounty.org on the "Request for Proposals" page. **All bids are to be returned separately, in sealed envelopes, plainly marked HMA Countywide Paving 25-17 and the name and address of the bidder.**

The public Bid Opening will take place in the offices of the *Ionia County Road Department of the County of Ionia, State of Michigan*, located at 170 E. Riverside Drive, Ionia, MI 48846.

At **11:00 AM on Friday, January 17, 2025**. Late bids will not be accepted. Sealed bids must be submitted to:

Ionia County Road Department
Attn: Cody Waite, Internal Coordinator
170 E. Riverside Drive
Ionia, Michigan 48846

The County of Ionia Board of Commissioners and Michigan Department of Transportation reserve the right to reject any and all proposals or to waive irregularities therein, and to accept any proposals which, in their opinion, may be most advantageous and in the best interest of the County of Ionia and Michigan Department of Transportation. Once bids

are opened, they become the property of the County of Ionia and may be subject to disclosure under the Freedom of Information Act. The cost of responding to this Bid Request will be solely the responsibility of the firm submitting the bid.

INSTRUCTIONS TO BIDDERS

Sealed bids will be publicly opened at the offices of the Ionia County Road Department of the County of Ionia, State of Michigan, located at 170 E. Riverside Drive, Ionia, MI 48846.

Refer to the INVITATION TO BID for the exact timing and for the identification of the bids as related to furnishing materials, services, equipment, work and/or supplies with the terms, conditions, specifications, drawings, plans and special provisions as stated herein.

Normal practice is to open and read the bids then refer the file to staff for tabulation and analysis. During this period, bid files are closed and will remain closed until presented to the Ionia County Board of Commissioners. Notifications of award, pending award, or other outcome, will be made in writing. The bid tabulation will accompany the award, as is customary for item bid, or may be requested by phone at (616) 527-1700.

1. Bids must be submitted on the County's blank form when provided. The bid shall be legibly prepared in ink or typed. The bidder must initial any erasures or alterations.
2. Specifications and plans should not be returned unless otherwise stated herein.
3. Bids shall be mailed or delivered. **Bids shall be in a sealed envelope identified on the outside as to the bid concerned and shall include the name and address of the bidder.** Bids sent via fax or email will NOT be accepted.
4. Bids will not be accepted after the time designated for the opening of the bids. The bidder shall assume full responsibility for delivery of bids prior to the appointed hour and shall assume the risk of late delivery or non-delivery regardless of the manner used for the transmission thereof. **Bids will be accepted at the Ionia County Road Department office**, on behalf of Ionia County, at any time during normal business hours only, said hours being 7:00 a.m. to 3:00 p.m., Monday through Friday, with the exception of legal holidays.
5. It is understood that the County of Ionia and the Michigan Department of Transportation (MDOT) are governmental units and as such, are exempt from the payment of all State and Federal taxes, except as allowed by the regulatory agencies to be included in the cost of materials and services.
6. The bidder, as evidenced by the execution of the bid form, thereby declares that the bid is made without collusion with any other person, firm, or corporation and agrees to furnish all bid items in strict adherence with all Federal regulatory measures.
7. The County of Ionia Board of Commissioners and the Michigan Department of Transportation reserve the right to reject any and all bids, to waive any irregularities therein, and to accept any bid which, in the opinion of the Board, may be most advantageous and in the best interest of the County. In case of error

in the extension of prices in the bid or other arithmetical error, the unit prices will govern.

8. Insurance Requirements: Upon request or notification of award, and prior to execution of the contract, the contractor shall have fourteen (14) days to submit to the County of Ionia a completed copy of their Certificate of Liability Insurance as evidence of the following specific requirements:

A. Indemnification: The contractor shall save harmless and indemnify the Michigan Department of Transportation, the County of Ionia as well as its officers, agents and employees, against all claims for damages to public or private property and for injuries to persons arising out of and during the progress and to the completion of the work all in accordance with the current Michigan Department of Transportation "Standard Specifications for Construction", section number 107.10.

B. CERTIFICATE HOLDER block shall read: "The County of Ionia, 101 W. Main Street, Ionia, Michigan 48846".

C. Worker's Compensation Insurance: The contractor shall carry Worker's Compensation Insurance of not less than the Statutory Limit.

D. Bodily Injury and Property Damage: The contractor shall afford protection against all claims for damages to public or private property, and injuries to persons, arising out of and during the progress of the work, and to its completion and, where specified in the proposal, similar insurance to protect the owner of premises on or near which construction operations are to be performed.

a. **Bodily Injury and Property Damage Other Than Automobile.** Unless otherwise specifically required by special provisions in the proposal, the minimum limits of property damage and bodily injury liability covering each contract will be:

Bodily Injury and Property Damage Liability:
Each Occurrence:
\$1,000,000
Aggregate
\$2,000,000

The insurance will include, but not be limited to coverage for:
Underground damage to facilities due to drilling and excavating with mechanical equipment, and collapse or structural injury to structures due to blasting or explosion, excavation, tunneling, pile driving, cofferdam work, or building moving or demolition.

b. **Bodily Injury Liability and Property Damage Liability Automobile.** Unless otherwise specifically required by special provision, the minimum limits of bodily injury liability and property damage liability shall be:

Each Person:
\$500,000

Each Occurrence:
\$1,000,000

Property Damage Liability:
Each Occurrence:
\$1,000,000

Combined Single Limit for Bodily Injury and property Damage Liability:
Each Occurrence;
\$2,000,000

- E. Comprehensive General Liability Insurance naming the County of Ionia, its Board members, officers, agents and employees, is required. This policy shall also include coverage for product liability and completed operations, and bodily or property damage due to perils of explosion, collapse and underground hazards (X, C, U). The completed certificate shall provide the name of the insurance company and its address, phone number, and fax number, in addition to the policy numbers, policy periods, policy descriptions, and signature of the insurance agent.

- F. Owner's Protective Public Liability Insurance: In the alternative to the previous section, the contractor shall provide for and on behalf of the County of Ionia, its Board members, officials, agents and employees, and any agencies specifically named below, and their employees, a policy for Owner's Protective Public Liability Insurance. Such insurance shall provide coverage and limits the same as the Contractor's Public Liability Insurance.

- 9. Cancellation of Contract Provisions: The County of Ionia shall have the right to cancel the contract for non-performance, should an inspection by the designated representative reveal that the contractor's work results in any non-acceptable condition of one or all specified areas. The designated representative at the time of the first circumstance shall call for a meeting with the contractor and issue a written warning of possible contract termination should the condition continue. If the condition should be repeated for a second time, written notice of termination shall be sent.

- 10. Presumption upon Receipt of Bid: Submission of bid will be construed as a conclusive presumption that the contractor is thoroughly familiar with the bid requirements and specifications and that he/she understands and agrees to abide by each, and all stipulations and requirements contained therein.

- 11. Contractor and Contractor's Subcontractor: Neither the contractor nor his/her subcontractors shall discriminate against any employee or applicant for employment, to be employed in the performance of this contract, with respect to his/her hire, tenure, terms, conditions or privileges of employment because of his/her race, color, religion, national origin, or ancestry. Breach of this covenant may be regarded as a material breach of this contract.

TITLE VI – THE IONIA COUNTY ROAD DEPARTMENT in accordance with Title VI of the Civil Rights Act of 1964, 78-252, 42 U.S.C. 2000d-2222d-4, the Civil Rights Act of 1987, P.L. 100-259, and Title 49, Code of Federal Regulations, Department of Transportation, subtitle A, Office of the Secretary, Part 21, Non-discrimination in federally assisted programs of the Department of Transportation issued pursuant to such Act, hereby notifies all bidders that it will affirmatively insure that in any contract entered into pursuant to this advertisement, Disadvantaged Business Enterprise firms will be afforded full opportunity to submit bids in response to this invitation and will not be discriminated against on the grounds of Race, Color, Sex, Age, National Origin, or Handicap in consideration for an award.

**Specifications for
Contract # 25-17 HMA Paving**

It is the intent of the County of Ionia to contract for HMA Paving, HMA Base Crushing and Shaping, Cold Milling HMA Surface, and Traffic Control on county primary and local roads in Ionia County for 2025. This contract may be extended for four (4) additional one-year terms, each renewal to be mutually agreed upon by all parties. Pricing, terms and conditions of the original contract will remain the same for any subsequent one-year renewal period.

This work shall be done in accordance with Sections 305, 501, and 812 of the MDOT 2020 Standard Specifications for Construction unless herein modified.

A. Description

The Contractor shall provide all materials, labor, and equipment necessary to perform the HMA re-surfacing items on various roads in Ionia County.

B. Materials

1. HMA Wedging and Skip Paving

The HMA, 5EL (or HMA, 36A alternative) will have a varying yield (wedging) of 0 to 220 pounds per square yard on the top courses the varies sites that include the paving.

2. HMA Paving

The **HMA**, 4EL (or **HMA**, 3C alternative) will have a yield of 275 pounds per square yard on base courses.

The HMA, 4EL (or HMA, 4C or HMA, 13A alternative) will have a yield of 165-220 pounds per square yard on top courses.

3. HMA Approach

HMA, 4C, 13A, or 4EL will be used for all driveway approaches. All driveway approaches will have a yield of 220 pounds per square yard.

4. Mix Criteria for all mixes in this contract:

- Design Air Voids shall be 4.0% and shall be regressed to 2.5% in production by the addition of virgin liquid asphalt.
- Target bitumen shall be 5.7% with a minimum of 5.5%.
- Total RAP binder by weight must not exceed 15% for any HMA mixture.
- The Minimum Fine Aggregate Angularity for any given HMA mixture shall be 40.0.
- The Minimum Crush Percentage for 4EL and 5EL HMA mixtures shall be 65%.
- The Aggregate Wear Index (AWI) for the top course shall be 260, minimum.
- The Performance Grade binder range for all HMA mixtures shall be PG 58-28.
- The Bond Coat material shall be per Section 501.02. The uniform rate of application between courses shall be 0.05 to 0.15 gallons per square yard, as directed by the Engineer.

5. Testing, Tolerances, and Penalties.

The ICRD will perform extraction and mechanical analysis tests at a rate of approximately every 1,000 tons of a particular mix provided. Testing will be performed by an independent, qualified, testing consultant. Samples will be taken, at random, from behind the truck of the site delivered mix.

The tolerance for bitumen content shall be -0.3% and +0.5% of target. For every 0.1% above or below the tolerance, the penalty will be -\$5.00 per ton of the respective as bid unit price.

The tolerance for particle size and crush content discrepancies shall be per Table 504-2 of the 2020 MDOT Standard Specifications for Construction. For every 1% above or below the tolerance, the penalty will be a deduction of \$5.00 per ton of the respective as bid unit price.

Penalties will be enforced after 2 consecutive failed extraction and/or mechanical analysis tests for any one mix type.

6. Aggregate Shoulders and Approaches

The contractor is to utilize MDOT 23A aggregate for all surface gravel proposed on shoulders and driveway.

C. **Construction**

1. Traffic Control

Where lane closures are needed, traffic shall be maintained with traffic regulators per MDOT Maintaining Traffic Typical 110-TR-NRW-2L or an ICRD approved alternative.

Road closures will only occur on crush and shape projects and will be signed by others. Each individual site will be paid for separately as the item, Traffic Control, per Each.

2. Cold Milling HMA Surface and Butt Joints

Locations and limits to be marked out by ICRD

Cold Milling HMA Surface lengths will be a minimum of 1,000 feet. Widths will be a minimum of 10 feet. Depths will vary from site to site.

All recycled asphalt within this contract, which is within Ionia County, is to be delivered to the nearest ICRD stock pile location. This will be either the Jordan Lake Road Garage at the corner of Jordan Lake Road and Grand River Avenue in Saranac or the Bugbee Pit which is off of Quarry Road, north of Riverside Drive in Ionia.

Butt Joints are to consist of cold milling a 1.5 inch to 2 inch depth joint of at least 3 feet in width over the entire width of the road as marked by the ICRD. Butt joints shall be paid as Pavt for Butt Joints, Rem (Syd). This work is to be done on the same day as the paving operation unless otherwise signed for traffic with the approval of the ICRD. No additional cost will be paid to the contractor for this requested signing.

This item also includes butt joints required on all asphalt approaches and as shown in the approach detail shown on the following sheet.

3. Pavement Removal

Pavement removal is to be performed on all locations where full depth concrete or asphalt removal is proposed. The maximum thickness of concrete or asphalt included in this item is 8 inches. This work is primarily on approach driveways constructed of concrete. Those concrete approaches are to be removed with the item Pavt, Rem per Syd and then replaced with approach paving items. See detail below regarding proposed driveway work.

CONCRETE DRIVEWAY DETAIL

Ex. Conc.

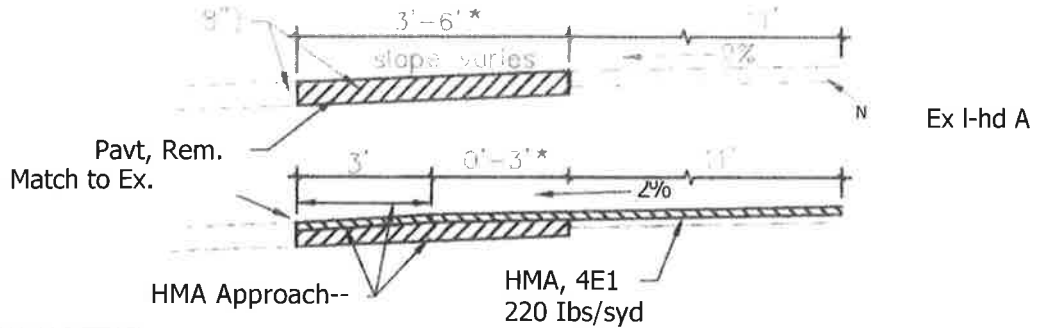

HMA DRIVEWAY DETAIL

Ex HMA

(depth varies 2"-6")

Cold Milling, HMA Surface-/
(butt joint)

Match to Ex.

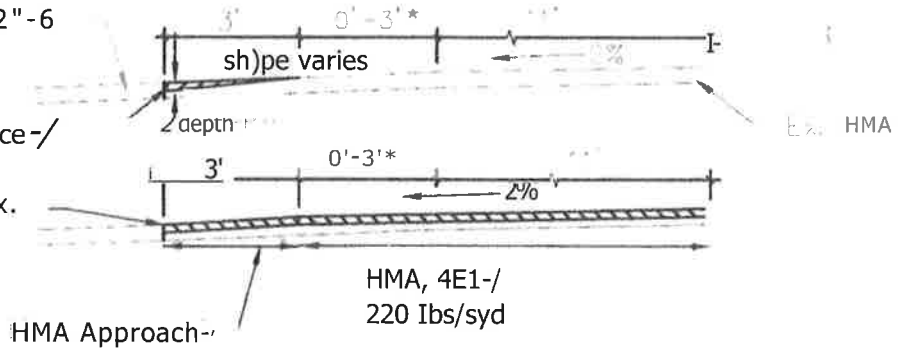

*The additional width only required on roads where paved shoulder is proposed

4. HMA Base Crushing and Shaping

Existing HMA thickness will range from 3 inches to 8 inches.

A rubber tired roller shall be used to achieve compaction to 98% of the maximum unit weight of the crushed material.

Some locations may have significant local traffic. The contractor is to monitor finished grade and repair traffic damaged areas as needed. Provide dust control as directed by the ICRD. Repair and dust control efforts are to be included within the HMA Base Crushing and Shaping item.

5. Wedging

Wedging will be performed on locations marked out by the ICRD. These locations will vary from 50 feet to 2,500 feet in length, 0 feet to 15 feet in width, and 0 to 220 pounds per square yard in yield.

The Contractor is to notify the ICRD prior to the any placement of HMA if the anticipated tonnage is over 10% of estimated quantity. Overage beyond 10% will not be paid for by the ICRD without written consent.

6. HMA Skip Paving

HMA skip paving will be performed on locations marked out by the ICRD before construction. These areas will be overlaid with top course HMA. Butt Joints may be required at each end of skip paving location if specified. Butt joints will be paid for per Pavt for Butt Joints, Rem item.

7. Paving HMA Base Course and HMA Top Courses

Paving will be performed on location marked out by the ICRD. All work will be performed in accordance with

The paving of all road approaches shall be considered under these mainline paving items

ROAD APPROACH DETAIL

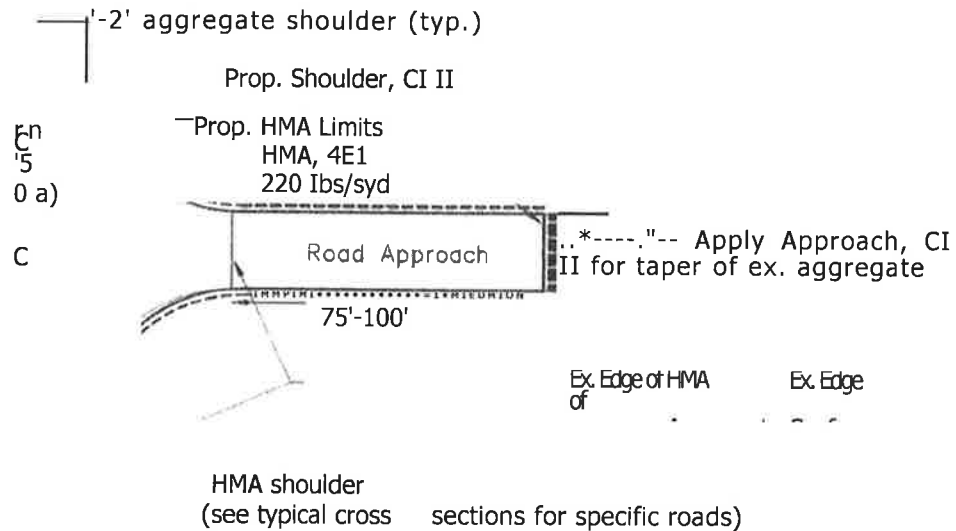

Notes:

Road approach aggregate shoulder is to be considered included in the item Shoulder,

The Contractor is to notify the ICRD prior to the any placement of HMA is anticipated tonnage is over 10% of estimated quantity. Overage beyond 10% will not be paid for by the ICRD without written consent.

8. HMA Valley Gutter

Valley gutter shall be constructed in areas designated by the ICRD. Valley gutter shall have a height of **4** inches and a width of 2 feet from the gutter line to the back edge of asphalt.

9. HMA Spillway

HMA spillways shall be constructed in areas designated by the ICRD. Spillways shall be hand placed at the direction of the ICRD. Size of spillways will vary from 2 to 7 square yards.

HMA spillways will be paid for per the as bid unit price for each location. The tonnage of asphalt used in each spillway will be included in the mainline paving tonnage.

10. HMA Approaches (driveways)

HMA approaches shall be paved per the direction of the ICRD after all mainline paving work has been completed.

HMA mix for approaches shall be the same as mainline HMA. HMA Approach will be paid for placement at driveways only. Intersection approaches will not be paid for separately but additional work will be considered included in payment for mainline paving quantities.

11. Aggregate Driveways and Road Approaches

After paving operation is complete, the contractor is to place Approach, CI II in accordance with the MDOT specifications for this item. Place approach on all existing gravel driveways and gravel road approaches in efforts to effectively match the existing driveway up to the new asphalt surface.

12. Aggregate Shoulders

After paving operation is complete, the contractor is to place Shld, CI II in accordance with the MDOT specifications for this item. A shoulder machine is to be utilized when placing aggregate shoulders.

D. **Method of Payment**

All associated materials, labor, and equipment necessary to complete the work for each respective item as specified herein shall be paid for at the as bid unit price below:

Ionia County Road Paving:

<u>Pay Item</u>	<u>Pay Unit</u>
Traffic Control (<i>per project site</i>)	Each
Pavt for Butt Joint, Rem	Square Yard
Cold Milling HMA Surface	Square Yard
Pavt, Rem	Square Yard
HMA Base Crushing and Shaping	Square Yard
HMA, 5EL or HMA, 36A (<i>wedging and skip paving</i>)	Ton
HMA, 4EL or HMA, 3C (<i>base course</i>)	Ton
HMA, 4EL or HMA, 4C or HMA, 13A (<i>top course</i>)	Ton
HMA Valley Gutter	Foot
HMA Spillway	Each
HMA Approach (<i>driveways</i>)	Ton
Approach, CI II	Ton
Shld, CI II	Ton

E. **Locations and Quantities:**

Paving locations cannot be identified at this time. The contractor is to note that this is an As-Needed Contract and there does exist the potential to add, change, or delete locations and quantity to this contract if needed by the ICRD.

Program to be determined in 2025

F. **Schedule**

The contractor shall notify the ICRD 48 hours prior to any work being performed and shall submit a schedule upon authorization.

In no case shall any work be commenced prior to receipt of formal notice of award by the Department.

All work associated with projects will begin no earlier than May 1 and be completed by November 1 of each given year.

Failure to meet these deadlines will result in liquidated damages of \$500 per calendar day until the project is complete.

**Questions concerning specifications may be directed in writing to Cody Waite
cwaite@ioniacountyroads.org**

Bid Form
Contract # 25-17 HMA Paving

Ionia County Road Paving

Item	Quantity	Unit	Unit Price	Total
Traffic Control	18	Each		
Pavt for Butt Joints, Rem	1,000	Syd		
Cold Milling HMA Surface	2,000 *	Syd		
Pavt, Rem	100	Syd		
MA Base Crushing and Shaping	16,550	Syd		
H MA, 5EL or HMA,36A (<i>wedging/skip paving</i>)	500 *	Ton		
HMA, 4EL or HMA, 3C (<i>base course</i>)	1,500	Ton		
HMA, 4EL, HMA, 4C or HMA, 13A (<i>top course</i>)	36,500	Ton		
HMAValley Gutter	500 *	Foot		
HMAFillway	2	Each		
HMAApproach (<i>driveways</i>)	500 *	Ton		
Approach, CI II	200	Ton		
Shld, CI II	5,000	Ton		
Riprap, Plain	10	Syd		
Slope Restoration	5,000 *	Syd		
Edge Trimming	3,060	Foot		
Driveway, Nonreinf Conc, 6 inch	80	Syd		
aved Ditch, HMA	40	Syd		
Dr Structure, 24 inch dia, Leaching	4	Each		
Dr Structure Cover, Type G	4	Each		
Ionia County Road Total				

* The quantity of these items is not known at this time but a unit price is being requested for potential work. Please assume the quantities shown above as a minimum amount if utilized in this contract.

Note: Additional work, at the submitted unit prices, may be requested by the ICRD at a later date.

Payment Terms:

INDEMNIFICATION: Contractor agrees to hold harmless and indemnify Ionia County, its commissioners and employees from any and all claims, suits and judgments to which the department, its commissioners or employees may be subject and for all costs and actual attorney fees which may be incurred arising out of any injury to persons or damage to property, including property of the department, whether due to negligence of the contractor or the joint negligence of the contractor and the department, arising out of the work specified in this proposal, or in connection with work not authorized in this proposal, or resulting from failure to comply with the term of this proposal. Contractor will not be obligated to indemnify the Road Department for Ionia County for any injury of property damage arising out of the sole negligence of the County, its commissioners, or employees. The Board of Commissioners reserve the right to accept or reject any or all bids, to waive irregularities in any proposal, to reduce or delete pay item quantities, and to make award in any manner deemed in the best interest of the County of Ionia.

Authorized Signature

Date

Print Name / Title

Phone Number

Company Name

Fax Number

Address

Cell Phone Number

City, State, ZIP