

## **NOTICE TO BIDDERS**

**Contract # 22-17  
HMA Paving**

The public Bid Opening will take place at the Ionia County Administrator's office, located at 101 W. Main Street, Ionia, Michigan 48846, at **1:00 PM on Thursday, August 25, 2022**. Sealed bids must be submitted to:

**County of Ionia  
Attn: Jason Eppler, Interim County Administrator  
101 West Main Street  
Ionia, Michigan 48846**

**All submissions must be received by 1:00 PM on Thursday, August 25, 2022, and must be clearly marked: "Contract # 22-17 HMA Paving".**

The contractor shall certify that all materials and equipment meet current Michigan Department of Transportation specifications. All bids will meet or exceed the specifications established by the Ionia County Road Department and/or the Michigan Department of Transportation.

Further information upon which bids shall be based is available at the [www.ioniacountyroads.org](http://www.ioniacountyroads.org) on the "Doing Business" page or at [www.ioniacounty.org](http://www.ioniacounty.org) on the "Request for Proposals" page. The bid form is to be returned in a sealed envelope and plainly marked "Sealed Bid for Contract # 22-17 HMA Paving" and shall include the name and address of the bidder.

The County of Ionia and/or Michigan Department of Transportation reserves the right to reject any and all proposals or to waive irregularities therein, and to accept any proposals which, in their opinion, may be most advantageous and in the best interest of the County of Ionia and the Michigan Department of Transportation.

## IONIA COUNTY ROAD DEPARTMENT

### INSTRUCTIONS TO BIDDERS

Sealed bids will be publicly opened at the Ionia County Administrator's office, located at 101 W. Main Street, Ionia, Michigan 48846.

Refer to the **NOTICE TO BIDDERS** for the exact timing and for the identification of the bids as related to furnishing materials, services, equipment, work and/or supplies with the terms, conditions, specifications, drawings, plans and special provisions as stated herein and hereto attached.

The Board's normal practice is to open and read the bids then refer the file to staff for tabulation and analysis. During this period, bid files are closed and will remain closed until presented to the Ionia County Road Department at their next regular meeting. Notifications of award, pending award, or other outcome, will be made in writing. The bid tabulation will accompany award, as is customary for item bid, or may be requested by phone at (616) 527-1700.

1. All bids must be submitted on the Board's blank form when provided. The bid shall be legibly prepared in ink or typewriter. Erasures or alterations must be initialed by the bidder.
2. Specifications and plans should not be returned unless otherwise stated herein.
3. **Bid shall be in a sealed envelope and identified on the outside as to the bid concerned.** Bids shall be mailed or delivered. Bids will NOT be accepted by fax or email.
4. Bids will not be accepted after the time designated for the opening of the bids. The bidder shall assume full responsibility for delivery of bids prior to the appointed hour for opening same and shall assume the risk of late delivery or non-delivery regardless of the manner employed for the transmission thereof. **Bids will be accepted at the Road Department office** on behalf of the Board at any time during normal business hours only, said hours being 6:00 a.m. to 4:00 p.m., Monday through Thursday, with the exception of legal holidays.
5. It is understood that the Ionia County Road Department is a governmental unit and as such, is exempt from the payment of all State and Federal taxes, except as allowed by the regulatory agencies to be included in the cost of materials and services.
6. The bidder, by execution of the bid form, thereby declares that the bid is made without collusion with any other person, firm or corporation and agrees to furnish all bid items in strict adherence with all Federal regulatory measures.
7. The County reserves the right to reject any and all bids, to waive any irregularities therein, and to accept any bid which, in the opinion of the County, may be most advantageous and to the best interest of the County. In case of error in the extension of prices in the bid or other arithmetical error, the unit prices will govern.

8. Insurance Requirements: Upon request or notification of award, and prior to execution of the contract, the contractor shall have fourteen (14) days to submit to the Ionia County Road Department a completed copy of the Certificate of Liability Insurance as evidence of the following specific requirements:

A. Indemnification: The contractor shall save harmless and indemnify Michigan Department of Transportation and the Ionia County Road Department as well as their officers, agents and employees, against all claims for damages to public or private property and for injuries to persons arising out of and during the progress and to the completion of the work all in accordance with the current Michigan Department of Transportation “Standard Specifications for Construction”, section number 107.10.

1. CERTIFICATE HOLDER block shall read: “Ionia County Road Department, 170 E. Riverside Drive, Ionia, Michigan 48846”.
2. DESCRIPTION OF OPERATIONS/LOCATIONS/VEHICLES/SPECIAL ITEMS block shall read: “Additional Insured: Ionia County, and its officers, agents and employees”.

B. Worker’s Compensation Insurance: The contractor shall carry Worker’s Compensation Insurance of not less than the Statutory Limit.

C. Bodily Injury and Property Damage: The contractor, will afford protection against all claims for damages to public or private property, and injuries to persons, arising out of and during the progress of the work, and to its completion and, where specified in the proposal, similar insurance to protect the owner of premises on or near which construction operations are to be performed.

1. **Bodily Injury and Property Damage Other Than Automobile.** Unless otherwise specifically required by special provisions in the proposal, the minimum limits of property damage and bodily injury liability covering each contract will be:

Bodily Injury and Property Damage Liability:

Each Occurrence .....	\$1,000,000
Aggregate .....	\$2,000,000

The Insurance will include, but not be limited to coverage for:

- a. Underground damage to facilities due to drilling and excavating with mechanical equipment, and
- b. Collapse or structural injury to structures due to blasting or explosion, excavation, tunneling, pile driving, cofferdam work, or building moving or demolition.

2. **Bodily Injury and Property Damage Liability Automobile.** Unless otherwise specifically required by special provision, the minimum limits of bodily injury liability and property damage liability shall be:

Bodily Injury Liability:

Each Person .....\$500,000  
 Each Occurrence .....\$1,000,000

Property Damage Liability:

Each Occurrence .....\$1,000,000

Combined Single Limit for Bodily Injury and Property Damage Liability:

Each Occurrence .....\$2,000,000

Comprehensive General Liability Insurance naming Ionia County, its commissioners, officers, agents and employees as “Additional Insured” is required as shown above. This policy shall also include coverage for product liability and completed operations, and bodily or property damage due to perils of explosion, collapse and underground hazards, X, C, and U. The completed certificate shall provide the name of the insurance company and its address, phone number, and fax number, in addition to the policy numbers, policy periods, policy descriptions, and signature of the insurance agent.

- D. Owner’s Protective Public Liability Insurance: In the alternative to the previous section, the contractor shall provide for and in behalf of the Ionia County, its commissioners, officials, agents and employees, and all agencies specifically named below, and their employees, a policy for Owner’s Protective Public Liability Insurance. Such insurance shall provide coverage and limits the same as the Contractor’s Public Liability Insurance.

The agencies specifically named are the Michigan Department of Transportation, Ionia County and the Ionia County Road Department.

9. Cancellation of Contract Provisions: Ionia County shall have the right to cancel the contract for non-performance, should an inspection by the designated representative reveal that the contractor’s work results in any non-acceptable maintenance condition of one or all specified areas. The designated representative at the time of the **first** circumstance shall call for a meeting with the contractor and issue a written warning of possible contract termination should the condition continue. If the condition should repeat for a **second** time, written notice of termination shall be sent.
10. Presumption upon Receipt of Bid: Submission of bid will be construed as a conclusive presumption that the contractor is thoroughly familiar with the bid requirements and specifications and that he/she understands and agrees to abide by each and all stipulations and requirements contained therein.

11. Contractor and Contractor's Subcontractor: Neither the Contractor nor his/her subcontractors shall discriminate against any employee or applicant for employment, to be employed in the performance of this contract, with respect to his/her hire, tenure, terms, conditions or privileges of employment because of his/her race, color, religion, national origin, or ancestry. Breach of this covenant may be regarded as a material breach of this contract.

## **Specifications for Contract # 22-17 HMA Paving**

It is the intent of the Ionia County Road Department (ICRD) to contract for HMA Paving, HMA Base Crushing and Shaping, Cold Milling HMA Surface, and Traffic Control on county primary and local roads in Ionia County for 2022 and 2023. This contract may be extended to 2024 with a negotiated increase for inflation.

There is also potential work on state trunk lines in Ionia, Barry, Allegan, Kent, Ottawa, Newaygo, or Montcalm Counties.

This work shall be done in accordance with Sections 305, 501, and 812 of the MDOT 2020 Standard Specifications for Construction unless herein modified.

### **A. Description**

The Contractor shall provide all materials, labor, and equipment necessary to perform the HMA re-surfacing items on various roads in Ionia County. This contract may be increased or decreased as needed by the ICRD throughout the remaining 2022 and entire 2023 construction seasons. The ICRD's maintenance contract with MDOT could greatly increase the quantities within this project if approved later in the season. Some state trunk line work may include work in neighboring counties within the MDOT Grand Region.

### **B. Materials**

#### **1. HMA Wedging and Skip Paving**

The HMA, 5EL (or HMA, 36A alternative) will have a varying yield (wedging) of 0 to 220 pounds per square yard on the top courses the varies sites that include the paving.

#### **2. HMA Paving**

The HMA, 4EL (or HMA, 3C alternative) will have a yield of 275 pounds per square yard on base courses.

The HMA, 4EL (or HMA, 4C or HMA, 13A alternative) will have a yield of 165-220 pounds per square yard on top courses.

#### **3. HMA Approach**

HMA, 4C, 13A, or 4EL will be used for all driveway approaches. All driveway approaches will have a yield of 220 pounds per square yard.

#### **4. Mix Criteria for all mixes in this contract:**

- Design Air Voids shall be 4.0% and shall be regressed to 2.5% in production by the addition of virgin liquid asphalt.
- Target bitumen shall be 5.7% with a minimum of 5.5%.
- Total RAP binder by weight must not exceed 15% for any HMA mixture.
- The Minimum Fine Aggregate Angularity for any given HMA mixture shall be 40.0.
- The Minimum Crush Percentage for 4EL and 5EL HMA mixtures shall be 65%.
- The Aggregate Wear Index (AWI) for the top course shall be 260, minimum.
- The Performance Grade binder range for all HMA mixtures shall be PG 58-28.
- The Bond Coat material shall be per Section 501.02. The uniform rate of application between courses shall be 0.05 to 0.15 gallons per square yard, as directed by the Engineer.

5. Testing, Tolerances, and Penalties.

The ICRD will perform extraction and mechanical analysis tests at a rate of approximately every 1,000 tons of a particular mix provided. Testing will be performed by an independent, qualified, testing consultant. Samples will be taken, at random, from behind the truck of the site delivered mix.

The tolerance for bitumen content shall be -0.3% and +0.5% of target. For every 0.1% above or below the tolerance, the penalty will be -\$5.00 per ton of the respective as bid unit price.

The tolerance for particle size and crush content discrepancies shall be per Table 504-2 of the 2020 MDOT Standard Specifications for Construction. For every 1% above or below the tolerance, the penalty will be a deduction of \$5.00 per ton of the respective as bid unit price.

Penalties will be enforced after 2 consecutive failed extraction and/or mechanical analysis tests for any one mix type.

6. Aggregate Shoulders and Approaches

The contractor is to utilize MDOT 23A aggregate for all surface gravel proposed on shoulders and driveway.

C. **Construction**

1. **Traffic Control**

Where lane closures are needed, traffic shall be maintained with traffic regulators per MDOT Maintaining Traffic Typical 110-TR-NRW-2L or an ICRD approved alternative.

Road closures will only occur on crush and shape projects and will be signed by others. Each individual site will be paid for separately as the item, Traffic Control, per Each.

2. **Cold Milling HMA Surface and Butt Joints**

Locations and limits to be marked out by ICRD.

Cold Milling HMA Surface lengths will be a minimum of 1,000 feet. Widths will be a minimum of 10 feet. Depths will vary from site to site.

**All recycled asphalt within this contract, which is within Ionia County, is to be delivered to the nearest ICRD stock pile location. This will be either the Jordan Lake Road Garage at the corner of Jordan Lake Road and Grand River Avenue in Saranac or the Bugbee Pit which is off of Quarry Road, north of Riverside Drive in Ionia.**

Butt Joints are to consist of cold milling a 1.5 inch to 2 inch depth joint of at least 3 feet in width over the entire width of the road as marked by the ICRD. Butt joints shall be paid as Pavt for Butt Joints, Rem (Syd). This work is to be done on the same day as the paving operation unless otherwise signed for traffic with the approval of the ICRD. No additional cost will be paid to the contractor for this requested signing.

This item also includes butt joints required on all asphalt approaches and as shown in the approach detail shown on the following sheet.

### 3. Pavement Removal

Pavement removal is to be performed on all locations where full depth concrete or asphalt removal is proposed. The maximum thickness of concrete or asphalt included in this item is 8 inches. This work is primarily on approach driveways constructed of concrete. Those concrete approaches are to be removed with the item Pavt, Rem per Syd and then replaced with approach paving items. See detail below regarding proposed driveway work.

#### CONCRETE DRIVEWAY DETAIL

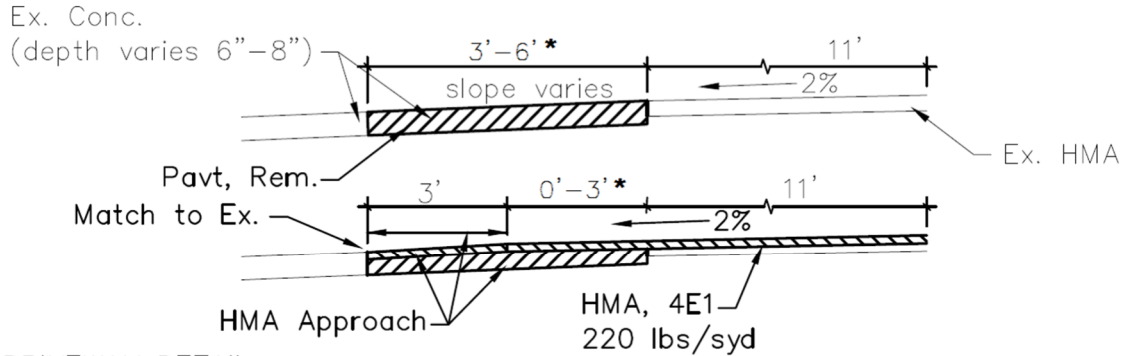

#### HMA DRIVEWAY DETAIL

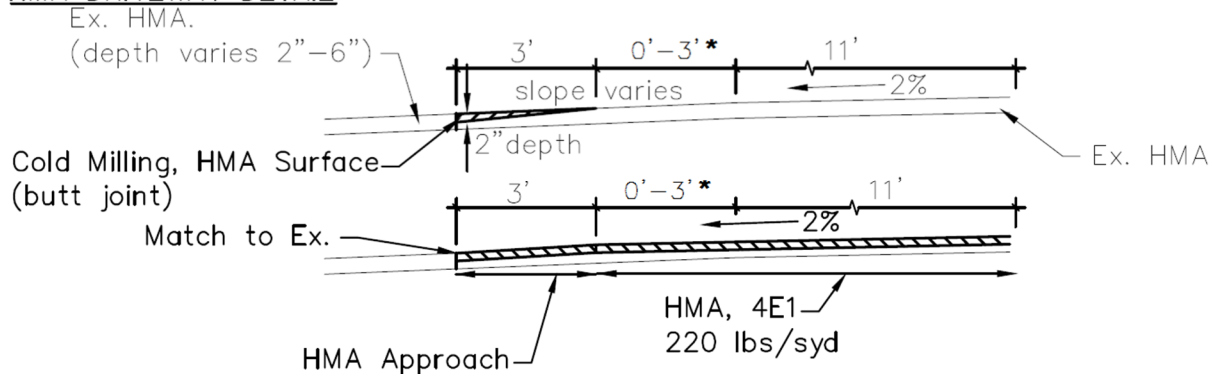

\* The additional width only required on roads where paved shoulder is proposed

### 4. HMA Base Crushing and Shaping

Existing HMA thickness will range from 3 inches to 8 inches.

A rubber tired roller shall be used to achieve compaction to 98% of the maximum unit weight of the crushed material.

Some locations may have significant local traffic. The contractor is to monitor finished grade and repair traffic damaged areas as needed. Provide dust control as directed by the ICRD. Repair and dust control efforts are to be included within the HMA Base Crushing and Shaping item.



**5. Wedging**

Wedging will be performed on locations marked out by the ICRD. These locations will vary from 50 feet to 2,500 feet in length, 0 feet to 15 feet in width, and 0 to 220 pounds per square yard in yield.

The Contractor is to notify the ICRD prior to the any placement of HMA if the anticipated tonnage is over 10% of estimated quantity. Overage beyond 10% will not be paid for by the ICRD without written consent.

**6. HMA Skip Paving**

HMA skip paving will be performed on locations marked out by the ICRD before construction. These areas will be overlaid with top course HMA. Butt Joints may be required at each end of skip paving location if specified. Butt joints will be paid for per Pavt for Butt Joints, Rem item.

**7. Paving HMA Base Course and HMA Top Courses**

Paving will be performed on location marked out by the ICRD. All work will be performed in accordance with

The paving of all road approaches shall be considered under these mainline paving items.

ROAD APPROACH DETAIL

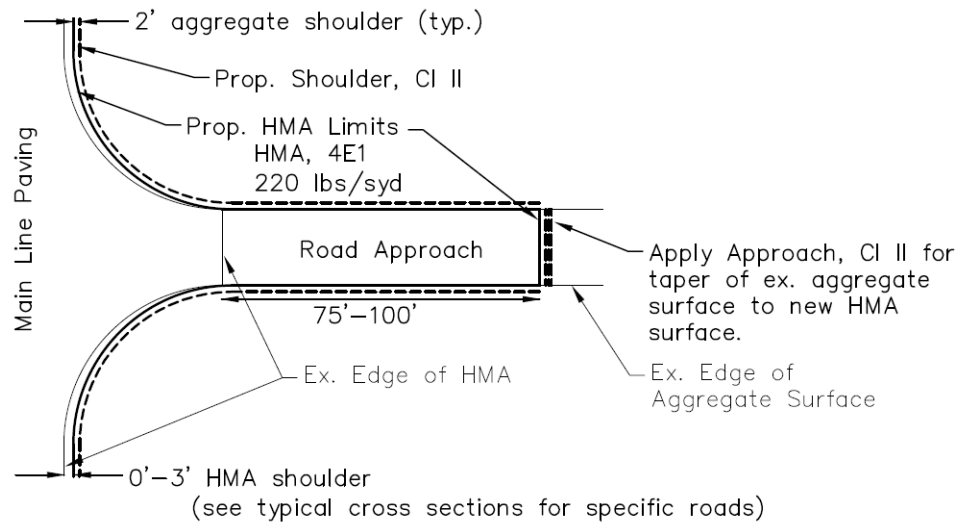

Notes:

Road approach aggregate shoulder is to be considered included in the item Shoulder,

The Contractor is to notify the ICRD prior to the any placement of HMA is anticipated tonnage is over 10% of estimated quantity. Overage beyond 10% will not be paid for by the ICRD without written consent.

**8. HMA Valley Gutter**

Valley gutter shall be constructed in areas designated by the ICRD. Valley gutter shall have a height of 4 inches and a width of 2 feet from the gutter line to the back edge of asphalt.

**9. HMA Spillway**

HMA spillways shall be constructed in areas designated by the ICRD. Spillways shall be hand placed at the direction of the ICRD. Size of spillways will vary from 2 to 7 square yards.

HMA spillways will be paid for per the as bid unit price for each location. The tonnage of asphalt used in each spillway will be included in the mainline paving tonnage.

**10. HMA Approaches (driveways)**

HMA approaches shall be paved per the direction of the ICRD after all mainline paving work has been completed.

HMA mix for approaches shall be the same as mainline HMA. HMA Approach will be paid for placement at driveways only. Intersection approaches will not be paid for separately but additional work will be considered included in payment for mainline paving quantities.

**11. Aggregate Driveways and Road Approaches**

After paving operation is complete, the contractor is to place Approach, Cl II in accordance with the MDOT specifications for this item. Place approach on all existing gravel driveways and gravel road approaches in efforts to effectively match the existing driveway up to the new asphalt surface.

**12. Aggregate Shoulders**

After paving operation is complete, the contractor is to place Shld, Cl II in accordance with the MDOT specifications for this item. A shoulder machine is to be utilized when placing aggregate shoulders.

**13. Corrugations, HMA (rumble strips)**

Work on state trunklines may require the need for centerline and shoulder corrugations as specified in MDOT Standard Plan R-112-J and section 822 of the MDOT standard specifications for construction. This work is to be paid for by the foot as measured, each strip individually.

**14. Pavement Marking**

Pavement marking may be required on state trunklines only. Work is to be performed per section 811 of the MDOT standard specifications for construction.

D. **Method of Payment**

All associated materials, labor, and equipment necessary to complete the work for each respective item as specified herein shall be paid for at the as bid unit price below:

**Ionia County Road Paving:**

<u>Pay Item</u>	<u>Pay Unit</u>
Traffic Control ( <i>per project site</i> )	Each
Pavt for Butt Joint, Rem	Square Yard
Cold Milling HMA Surface	Square Yard
Pavt, Rem	Square Yard
HMA Base Crushing and Shaping	Square Yard
HMA, 5EL or HMA, 36A ( <i>wedging and skip paving</i> )	Ton
HMA, 4EL or HMA, 3C ( <i>base course</i> )	Ton
HMA, 4EL or HMA, 4C or HMA, 13A ( <i>top course</i> )	Ton
HMA Valley Gutter	Foot
HMA Spillway	Each
HMA Approach ( <i>driveways</i> )	Ton
Approach, CI II	Ton
Shld, CI II	Ton

**State Trunkline (M-Routes and Interstate) Paving within Ionia County:**

<u>Pay Item</u>	<u>Pay Unit</u>
Traffic Control ( <i>per project site</i> )	Each
Cold Milling HMA Surface	Square Yard
Pavt for Butt Joint, Rem	Square Yard
Pavt, Rem	Square Yard
HMA, 4EML ( <i>PG 64-28</i> )	Ton
Corrugations, HMA ( <i>centerline and/or shoulder</i> )	Foot
Pavt Mrkg, Waterborne, 6 inch, White	Foot
Pavt Mrkg, Waterborne, 4 inch, Yellow	Foot

**State Trunkline (M-Routes and Interstate) Paving outside of Ionia County but within the MDOT Grand Region (Allegan, Barry, Kent, Montcalm, Newago, or Ottawa Counties):**

<u>Pay Item</u>	<u>Pay Unit</u>
Traffic Control ( <i>per project site</i> )	Each
Cold Milling HMA Surface	Square Yard
Pavt for Butt Joint, Rem	Square Yard
Pavt, Rem	Square Yard
HMA, 4EML ( <i>PG 64-28</i> )	Ton
Corrugations, HMA ( <i>centerline and/or shoulder</i> )	Foot
Pavt Mrkg, Waterborne, 6 inch, White	Foot
Pavt Mrkg, Waterborne, 4 inch, Yellow	Foot

E. **Locations and Quantities:**

Some paving locations can be identified at this time. The contractor is to note that this is an As-Needed Contract and there does exist the potential to add, change, or delete locations and quantity to this contract if needed by the ICRD.

These projects and others are to take place in both 2022 and 2023. Tentatively known locations are:

**2022**

<b><u>Project #</u></b>	<b><u>Road(s)</u></b>	<b><u>Item</u></b>	<b><u>Qty</u></b>	<b><u>Pay Unit</u></b>
<b>22-01</b>	<b>Pearl Barr 1 / Carriage Lane – Danby Township</b> <i>Reconstruction from Kent Street to 1<sup>st</sup> Turn Around</i> <i>0.29 miles</i>	Traffic Control	1	Each
		HMA Crushing & Shaping	5,900	Syd
		Pavt, Rem	80	Syd
		HMA, 4EL	1,020	Ton
		Edge Trimming	3,060	Foot
		Dr Struct, 24 inch, Leaching	4	Each
		Driveway, Nonreinf Conc	80	Syd
	Slope Restoration	2,000	Syd	
<b>22-02</b>	<b>Johnson Road – Easton Township</b> <i>overlay from Ellison Road to Potters Road</i> <i>2.50 miles</i>	Traffic Control	1	Each
		HMA, 4EL	5,326	Ton
		Shd, CI II	528	Ton
<b>22-03</b>	<b>Johnson Road – Easton Township</b> <i>overlay from Potters Road to M-21</i> <i>1.68 miles</i>	Traffic Control	1	Each
		HMA, 4EL	2,860	Ton
		Shld, CI II	355	Ton
<b>22-04</b>	<b>Long Lake Rd/Allan Rd/Van Vleck Rd – Ronald Township</b> <i>overlay from M-66 to Judevine Road</i> <i>4.88 miles</i>	Traffic Control	1	Each
		HMA, 4EL	8,305	Ton
		Shld, CI II	1,030	Ton
<b>22-05</b>	<b>Musgrove Highway – Odessa Township</b> <i>overlay from Jordan Lake Road to M-66</i> <i>3.00 miles</i>	Traffic Control	1	Each
		HMA, 4EL	5,959	Ton
		Shld, CI II	633	Ton
<b>22-06</b>	<b>Nash Highway – Campbell Township</b> <i>overlay from Clarksville Village Limits to M-50</i> <i>2.53 miles</i>	Traffic Control	1	Each
		HMA, 4EL	5,029	Ton
		Shld, CI II	534	Ton
<b>22-07</b>	<b>Vernier Road – North Plains Township</b> <i>overlay from Culvert to Crossing</i> <i>0.05 miles</i>	Traffic Control	1	Each
		HMA, 4EL	85	Ton
		Shld, CI II	11	Ton
<b>22-08</b>	<b>Keefer Highway – Village of Lyons</b> <i>Box Culvert North of Goodwin Road</i> <i>0.03 miles</i>	Traffic Control	1	Each
		HMA, 4EL	75	Ton
		Shld, CI II	50	Ton
<b>22-09</b>	<b>Johnson Rd &amp; Long Lake Rd Intersection – Orleans Twp</b>  <i>0.03 miles</i>	Traffic Control	1	Each
		HMA, 4EL	75	Ton
		Shld, CI II	50	Ton

<b>Project #</b>	<b>Road(s)</b>	<b>Item</b>	<b>Qty</b>	<b>Pay Unit</b>
<b>22-10</b>	<b>Irish Street – Village of Lyons</b> <i>overlay (2") from Felch Street South to Village Limits</i> <i>0.23 miles</i>	Traffic Control	1	Each
		Pavt For Butt Joint, Rem	100	Syd
		HMA, 13A	375	Ton
		Approach, CI II	10	Ton
		HMA Spillway	2	Ea
		Riprap, Plain	10	Syd
<b>22-11</b>	<b>Burgess Street – Village of Lyons</b> <i>overlay (2") from Felch Street North to Isham Street</i> <i>0.19 miles</i>	Traffic Control	1	Each
		Pavt For Butt Joint, Rem	130	Syd
		HMA, 13A	280	Ton
		Approach, CI II	30	Ton
<b>22-12</b>	<b>Burgess Street – Village of Lyons</b> <i>overlay (2") from Isham Street North to Bridge Street</i> <i>0.07 miles</i>	Traffic Control	1	Each
		Pavt For Butt Joint, Rem	75	Syd
		HMA, 13A	125	Ton
		Approach, CI II	10	Ton
<b>22-13</b>	<b>W. Isham Street – Village of Lyons</b> <i>overlay (2") from Baldwin Street East to Irish Street</i> <i>0.13 miles</i>	Traffic Control	1	Each
		Pavt For Butt Joint, Rem	120	Syd
		HMA, 13A	200	Ton
		Approach, CI II	10	Ton
<b>22-14</b>	<b>E. Isham Street – Village of Lyons</b> <i>Overlay (2") from John Street East to Tabor Street</i> <i>0.30 miles</i>	Traffic Control	1	Each
		Pavt For Butt Joint, Rem	235	Syd
		HMA, 13A	480	Ton
		Approach, CI II	20	Ton
<b>22-15</b>	<b>Virginia Ave &amp; Shirlee Ave + Gravel Rd– Ionia Township</b> <i>Overlay (2") loop from M-66 to M-66</i> <i>0.24 miles</i>	Traffic Control	1	Each
		HMA, 4EL	380	Ton
		Shld, CI II	50	Ton
<b>22-16</b>	<b>Clarksville Road – Sebewa Township</b> <i>overlay from M-66 to Sunfield Road</i> <i>4.05 miles</i>	Traffic Control	1	Each
		HMA, 4EL	6,898	Ton
		Shld, CI II	855	Ton
<b>22-17</b>	<b>Catalpa Drive – Orleans Township</b> <i>Reconstruction from Flannigan (Long Lake Rd) to Cul-De- Sac</i>  <i>0.34 miles</i>	Traffic Control	1	Each
		HMA Crushing & Shaping	2,650	Syd
		HMA, 4EL	500	Ton
		Shld, CI II	150	Ton
<b>22-18</b>	<b>Bricker Road – Orleans Township</b> <i>Reconstruction from Lakeview Drive East to Gravel</i> <i>0.57 miles</i>	Traffic Control	1	Each
		HMA Crushing & Shaping	8,000	Syd
		HMA, 4EL	1,400	Ton
		Shld, CI II	250	Ton

\*HMA, 4C or 13A will be an allowable alternative. RAP and binder specifications still apply.

**2023**

**Project # Road(s)**

**Program to be determined in January 2023**

**F. Schedule**

The contractor shall notify the ICRD 48 hours prior to any work being performed and shall submit a schedule upon authorization.

In no case shall any work be commenced prior to receipt of formal notice of award by the Department, or as agreed upon by the Engineer.

All work associated with MDOT projects must be completed and invoiced by September 30 of that fiscal year.

All work associated with projects will begin no earlier than May 11 and be completed by November 1 of each given year.

Failure to meet these deadlines will result in liquidated damages of \$500 per calendar day until the project is complete.

Questions concerning specifications may be directed to Connie Houk, P.E. at (231) 468-3456 or [chouk@preinnewhof.com](mailto:chouk@preinnewhof.com).

**Bid Form**  
**Contract # 22-17 HMA Paving**  
**Page 1 of 3**

**Ionia County Road Paving 2022 and 2023**

<u>Item</u>	<u>Quantity</u>	<u>Unit</u>	<u>Unit Price</u>	<u>Total</u>
Traffic Control	18	Each		
Pavt for Butt Joints, Rem	1,000	Syd		
Cold Milling HMA Surface	2,000 *	Syd		
Pavt, Rem	100	Syd		
HMA Base Crushing and Shaping	16,550	Syd		
HMA, 5EL or HMA, 36A ( <i>wedging/skip paving</i> )	500 *	Ton		
HMA, 4EL or HMA, 3C ( <i>base course</i> )	1,500	Ton		
HMA, 4EL, HMA, 4C or HMA, 13A ( <i>top course</i> )	36,500	Ton		
HMA Valley Gutter	500 *	Foot		
HMA Spillway	2	Each		
HMA Approach ( <i>driveways</i> )	500 *	Ton		
Approach, CI II	200	Ton		
Shld, CI II	5,000	Ton		
Riprap, Plain	10	Syd		
Slope Restoration	5,000 *	Syd		
Edge Trimming	3,060	Foot		
Driveway, Nonreinf Conc, 6 inch	80	Syd		
Paved Ditch, HMA	40	Syd		
Dr Structure, 24 inch dia, Leaching	4	Each		
Dr Structure Cover, Type G	4	Each		

**Ionia County Road Total**

--

\* The quantity of these items is not known at this time but a unit price is being requested for potential work. Please assume the quantities shown above as a minimum amount if utilized in this contract.

Note: Additional work, at the submitted unit prices, may be requested by the ICRD at a later date.

**Bid Form**  
**Contract # 22-17 HMA Paving**  
**Page 2 of 3**

**State Trunkline Paving within Ionia County**

<u>Item</u>	<u>Quantity</u>	<u>Unit</u>	<u>Unit Price</u>	<u>Total</u>
Traffic Control	1 *	Each		
Cold Milling HMA Surface	1,200 *	Syd		
Pavt for Butt Joints, Rem	50 *	Syd		
HMA, 4EML	132 *	Ton		
Corrugations, HMA	3,000 *	Foot		
Pavt Mrkg, Waterborne, 6 inch, White	2,640 *	Foot		
Pavt Mrkg, Waterborne, 4 inch, Yellow	1,320 *	Foot		

**State Trunkline in Ionia County Total**

**State Trunkline Paving outside Ionia County but within the MDOT Grand Region**

<u>Item</u>	<u>Quantity</u>	<u>Unit</u>	<u>Unit Price</u>	<u>Total</u>
Traffic Control	1 *	Each		
Cold Milling HMA Surface	1,200 *	Syd		
Pavt for Butt Joints, Rem	50 *	Syd		
HMA, 4EML	132 *	Ton		
Corrugations, HMA	3,000 *	Foot		
Pavt Mrkg, Waterborne, 6 inch, White	2,640 *	Foot		
Pavt Mrkg, Waterborne, 4 inch, Yellow	1,320 *	Foot		

**State Trunkline outside Ionia County but within MDOT Grand Region Total**

\*The quantity of these items is not known at this time but a unit price is being requested for potential work. Please assume the quantities shown above as a minimum amount if utilized in this contract.

Note: Additional work, at the submitted unit prices, may be requested by the ICRD at a later date.

Ionia County projects, MDOT projects within Ionia County and MDOT projects outside Ionia County may all be awarded separately in the best interest of the Ionia County Road Department and MDOT.



**Bid Form**  
**Contract # 22-17 HMA Paving**  
**Page 3 of 3**

***Indemnification:** Contractor agrees to hold harmless and indemnify the Michigan Department of Transportation and the Ionia County Road Department as well as their officers, agents and employees, against all claims, suits, and judgments to which the Department, its commissioners, or employees may be subject and for all costs and actual attorney fees which may be incurred arising out of any injury to persons or damage to property, including property of the Department, whether due to negligence of the contractor or the joint negligence of the contractor and the Department, arising out of the work specified in this proposal, or in connection with work not authorized in this proposal, or resulting from failure to comply with the terms of this proposal. Contractor will not be obligated to indemnify the Ionia County Road Department for any injury or property damage arising out of the sole negligence of the Ionia County Road Department, its officers, agents, or employees.*

---

Authorized Signature

---

Date

---

Print Name / Title

---

Phone Number

---

Company Name

---

Fax Number

---

Address

---

Cell Phone Number

---

City, State, ZIP

---

Email address

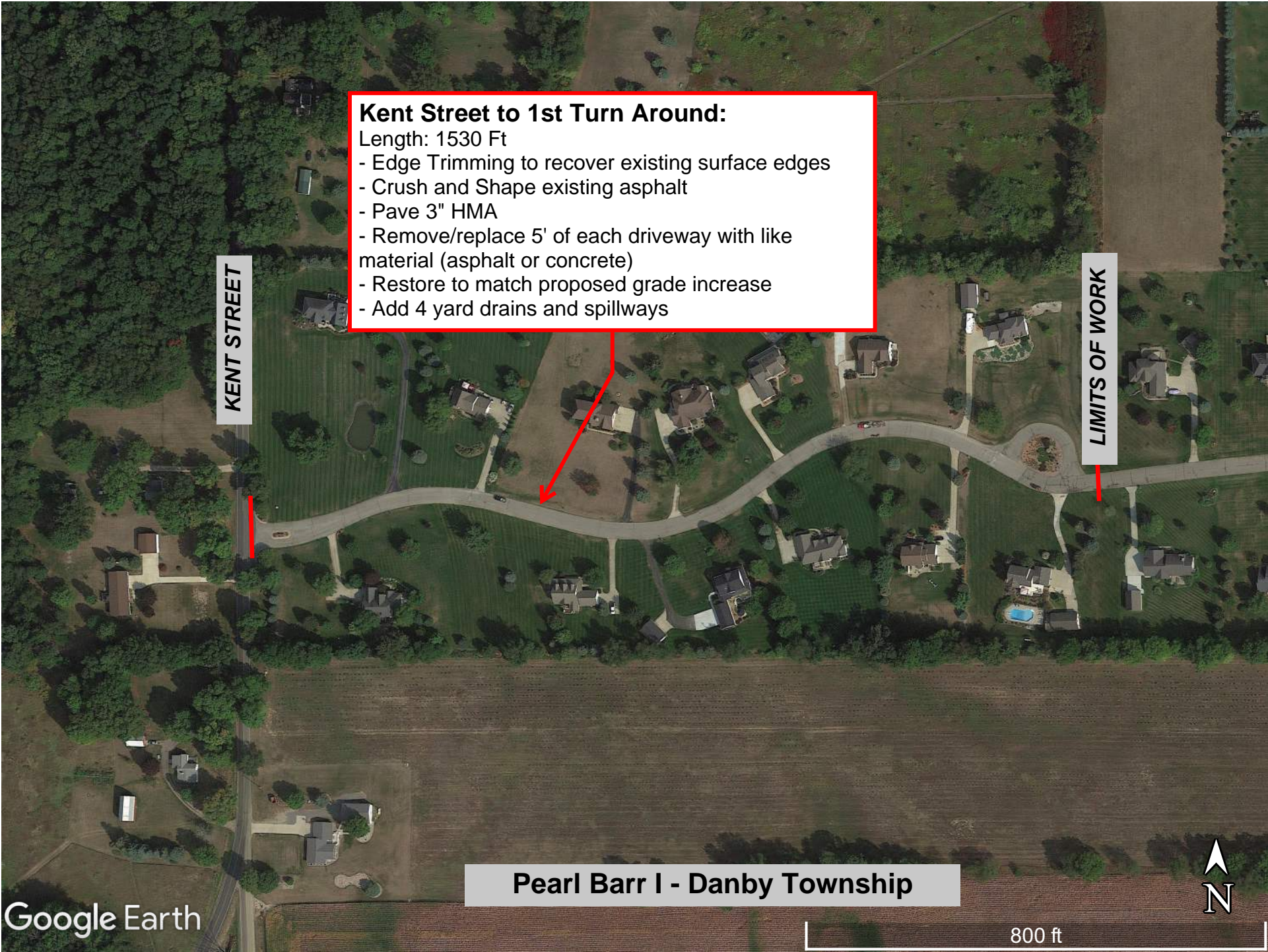

**Kent Street to 1st Turn Around:**  
 Length: 1530 Ft

- Edge Trimming to recover existing surface edges
- Crush and Shape existing asphalt
- Pave 3" HMA
- Remove/replace 5' of each driveway with like material (asphalt or concrete)
- Restore to match proposed grade increase
- Add 4 yard drains and spillways

**KENT STREET**

**LIMITS OF WORK**

**Pearl Barr I - Danby Township**

Google Earth

800 ft

